

- PARTS LIST**
1. COLLECTION CUP LID
 2. COLLECTION CUP
 3. CLEAR VINYL TUBING 1/2"
 4. PROTEIN SKIMMER BODY
 5. MANIFOLD
 6. SKIMMER PUMP
 7. MAIN FILTER UNIT
 8. BLUE FOAM BLOCK
 9. EGG CRATE SHELF
 10. DRIP TRAY
 11. LID
 12. BUBBLE TRAP
 13. THREADED SLIP FITTING
 14. RUBBER SEAL
 15. THREADED 90 DEGREE ELBOW
 16. BLUE POLYESTER
 17. BLUE BIO-BALLS
 18. FLEX HOSE

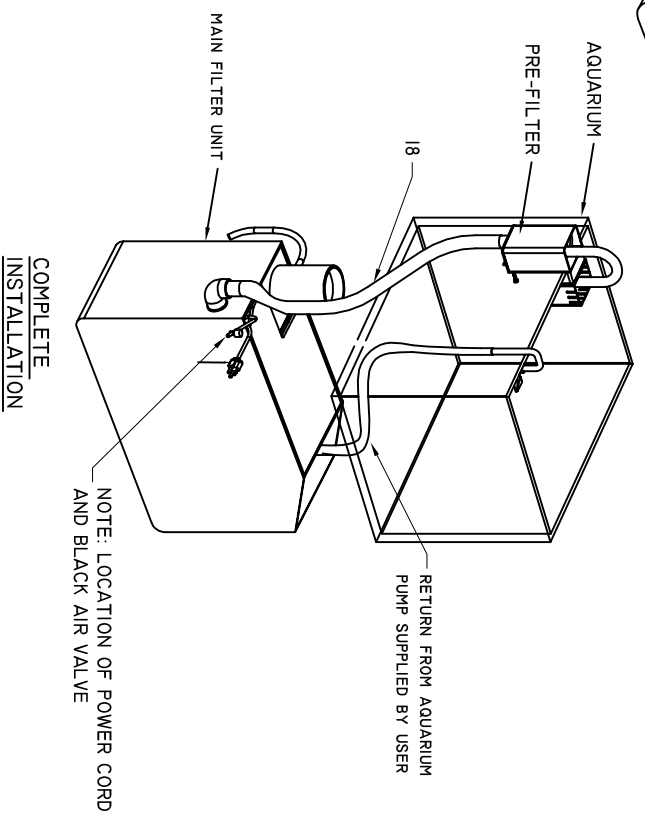

PRO 150 SERIES FIGURE 2



PRO SERIES 150 ASSEMBLY AND INSTALLATION INSTRUCTIONS

The Pro 150 Series Wet/Dry is designed with the input water from the tank being skimmed before going to the Biological area. This has the advantage of higher Biological activity and increased oxygenation of the aquarium water. Make sure the skimmer section of the filter maintains a consistent water level that is high enough to mount any heaters or chiller probes vertically. The sump contains a foam water-polishing block to prevent any smaller debris from being returned to the aquarium.

ASSEMBLY:

1. Remove the skimmer pump, Item 6, from the box, and connect pump to manifold, Item 5 using a discharge adapter. Ensure vinyl tube with the black air valve is installed on the elbow on the pump. Place the pump into the main filter unit, Item 7, behind the back divider. Note: the suction cups are not used.
2. Remove the bubble trap, Item 12, from the thread slip fitting, Item 13, and threaded 90 degree elbow, Item 15, with rubber seal, Item 14. Install the threaded 90 degree elbow with rubber seal outside to the 1 1/4" hole in the rear of filter tank unit, tightening threaded slip fitting hand tight from inside filter tank unit. (Do not over tighten!)
3. Install the protein skimmer body, Item 4, over the manifold, Item 5, on the pump
4. Place the main filter unit with protein skimmer under the aquarium stand at desired location.
5. Hang the pre-filter box Item B — Fig. 1 on the back of the aquarium with the skimmer box, Item A — Fig. 1, inside the aquarium. Adjust the skimmer box inside the aquarium as required. Tighten nylon screw, Item E — Fig.1, once adjusted.
6. Place the siphon tube Item C — Fig. 1, in the pre-filter box, Item B- Fig. 1. Note: the siphon tube goes down the side not inside the pre-filter sponge.

OPERATION:

1. Fill the aquarium with water until the water begins to fill the skimmer box, Item A — Fig. 1.
2. Fill the pre-filter box, Item B — Fig. 1, with water using the siphon hose, Item C — Fig. 1, until half the box is full.
3. Insert the length of vinyl siphoning hose, Item G — Fig 1, supplied with the pre-filter unit, until it is approximately half way into the bend of the siphon tube, Item C — Fig. 1.
4. Start siphoning by sucking on the vinyl siphoning hose, Item G, to remove excessive air. By natural forces, the water should begin draining from the aquarium into the pre-filter box, Item B, - Fig. 1. To remove the vinyl siphoning hose, Item G, pinch the end of the tube to prevent air from being drawn back into the siphon tube. With one hand hold the siphon tube, Item C, in the pre-filter box and pull the vinyl siphoning hose completely out with the other hand. Any remaining air bubbles can be removed by jiggling the siphon tube once the system is running. Should the siphon process fail, repeat the above procedure.

5. If the filter tank has not filled with enough water to cover the pump, add more water directly to the filter tank. Once the pump is totally submerged with water, you can start the pump. Continue adding water until the pump no longer drains the sump or filter dry, or blows air out of the return spout. Water level in the filter tank should be at the bottom of the egg crate shelf, Item 9— Fig.3. Add or remove water as necessary. NOTE: The indicated level on your filter is the minimum water level, for the system to operate properly. The system is now operational
6. To check the system, turn off the pump and let the system stop. After a few minutes, check the siphon tube in the pre-filter box, it should have not lost its siphon. If the siphon is lost, make sure the siphon hose is completely down in skimmer box and pre-filter box and both ends of siphon tube are submerged in water.

WITH SYSTEM IN OPERATION, CHECK THE FOLLOWING:

- Adjust the water level if required. You can adjust the water level by lowering the skimmer box.
- Add or remove water as required. NOTE: the leveling screw, Item D - Fig. 1, at the bottom of the pre-filter box is used to bring pre-filter box parallel with the water level. This allows even water flow through all slots in the pre-filter box. However, the pre-filter may initially fill with water, but once the pre-filter sponge, Item H Fig. 1, becomes saturated with water, the water level will fall some.

MAINTENANCE:

- This should be performed as required. Algae should not be allowed to build up on any of the pre-filter parts including the siphon tube. The foam block, Item 8 — Fig. 3, in the main filter should be removed and rinsed in discard water when performing a water change on the aquarium. Pre-filter sponge, Item H — Fig. 1, should be cleaned at least once a week (every three days is recommended). The pump should be removed and the impeller assembly cleaned at least monthly.
- Any evaporation-taking place in the aquarium will be transferred to the sump area causing the water level in the sump to drop. Fresh water must be added to the sump as needed to prevent it from running dry and to maintain constant salinity, in the case of a salt water aquarium.

This Pro Clear Aquatic Systems product is covered by a Limited Lifetime Warranty for the original purchaser against defects in materials or workmanship (receipt required).